

USATCO's 15-A1080 Portable Air Vac

Item No.	Part No.	Part
1	38-AVP1	Vac Body with Flapper
2	38-AVP2	Valve Housing
3	38-AVP3	*Seal
4	38-AVP4	*Valve with "O" Ring
5	38-AVP5	Lever
6	38-AVP6	Lever Retainer
7	38-AVP7	*Clamp for Bag
8	38-AVP8	*Vac Bag
9	38-AVP9	Closing Clip
10	38-AVP10	*Spring
11	38-AVP1A	Flapper with Screw and Washer
12	38-AVP4A	"O" Ring

*No. 53-AVPK...Parts Kit - Containing parts indicated noted with asterisk.

Operating pressure:
60-100 lbs. (27.22 - 40.82 kg.)

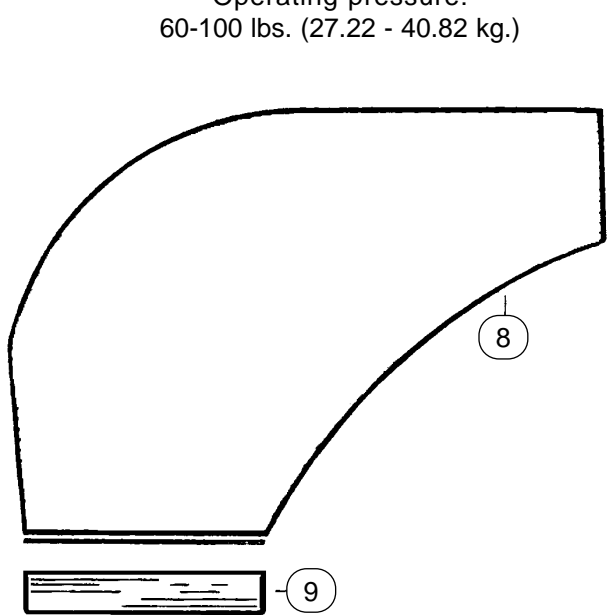

*Complete Kit No. 53-A1080 Shown

Optional:

**Item 2-B/Part No. 38-AVP2-B "Fully-On" Air Flow Plug Useful in situations where "On-Off" control is done manually.

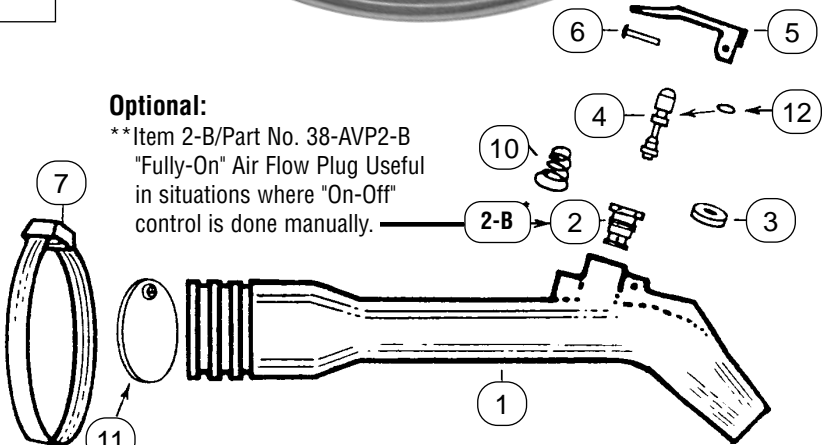

Accessories:

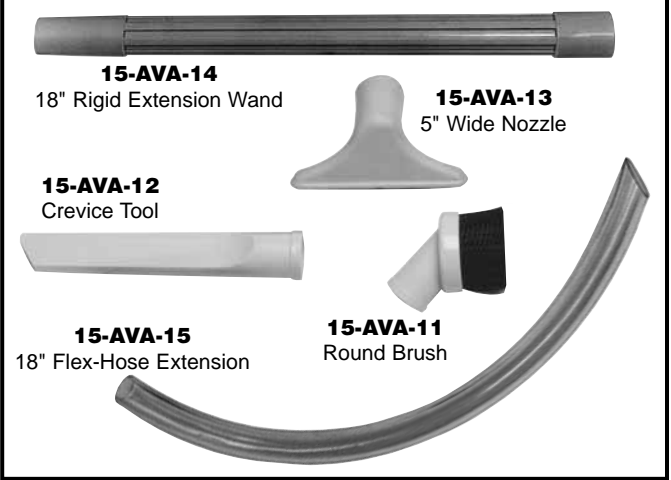

AIR VAC Model No. 53-A1080

Complete Kit Includes:

- Air Vac • Round Brush
- Slim Crevice Tool • 5" Wide Nozzle

AIR VAC Model No. 53-A1082

Complete Kit Includes:

- Air Vac • 18" Flex-Hose Extension

AIR VAC Model No. 53-A1092

Complete Kit Includes:

- Air Vac • 18" Rigid Extension Wand
 - Slim Crevice Tool • Round Brush
- NSN 7910-00-807-3704

USATCO\U.S. Air Tool Company, Inc.

Eastern Division60 Fleetwood Ct., Ronkonkoma, NY 11779-6951 tel: (631) 471-3300 fax: (631) 471-3308

Western Division1219 W. Mahalo Place, Rancho Dominguez, CA 90220-5446 tel: (310) 632-5400 fax: (310) 632-3900