



## MAPS-01 Rivet Stem Shaver

*Corebolt break-off shaving & milling tools designed for use with Visu-Lok, Composi-Lok & Radial-Lok fasteners.*



- Shaves pintail protrusions to meet aircraft flushness requirements
- 30,000 RPM promotes swift pintail 'slicing'
- Cutting depth adjustment increments of .001"
- Economical cutting discs
- Lightweight (1-1/4 lbs.)
- One-handed operation

A unique and easily operated tool for shaving corebolt break-offs on Composi-Lok and Visu-Lok fasteners where flushness requirements must be met. Unlike traditional, dual-rotation carbide milling units, the shaver actually slices the corebolt, producing uninterrupted cuts and minimal vibration. Additionally, disc changeover is economical, quick and trouble free. A very user-friendly and efficient tool.

### Shaving Procedure

1. Adjust shaver to desired cutting depth. It is always best to check for over-adjustment before using the shaver on your primary surface. This may be achieved by running it on a flat scrap piece of metal. If disc abrasions occur, depth is over-adjusted. Re-adjust until cutting disc no longer contacts metallic surface.
2. Position the shaver so that pintail (corebolt) guard is directly over the pintail of the fastener. Make sure shaver is resting flat on the structure's surface, then release safety lever and bring motor to full rpm.
3. While using very slight end pressure, slowly move shaver over the pintail and begin cutting. Let the shaver 'walk' through the pintail material; excessive end pressure by the operator may result in a fractured disc or binding of the motor spindle.
4. Continue cutting until pintail has been completely sliced off.

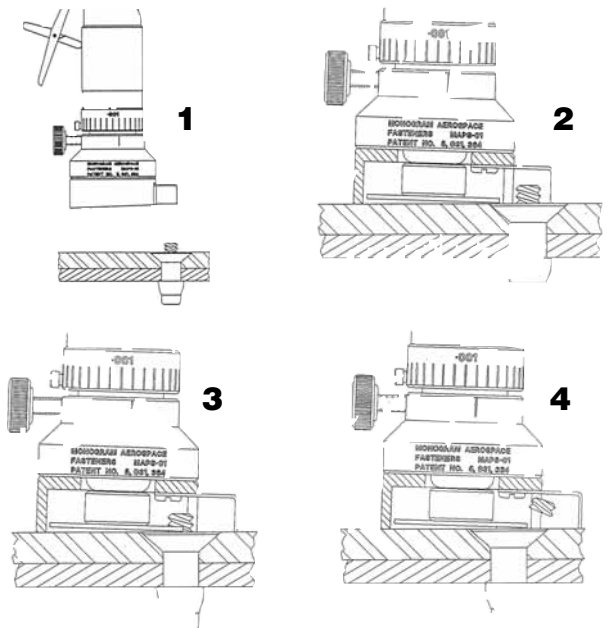

Toll Free Nationwide & Canada: **800-645-8180**

USATCO\U.S. AIR TOOL COMPANY, INC. [www.USATCO.COM](http://www.USATCO.COM) NEW YORK • CALIFORNIA

# Exploded View of Major Shaver Components

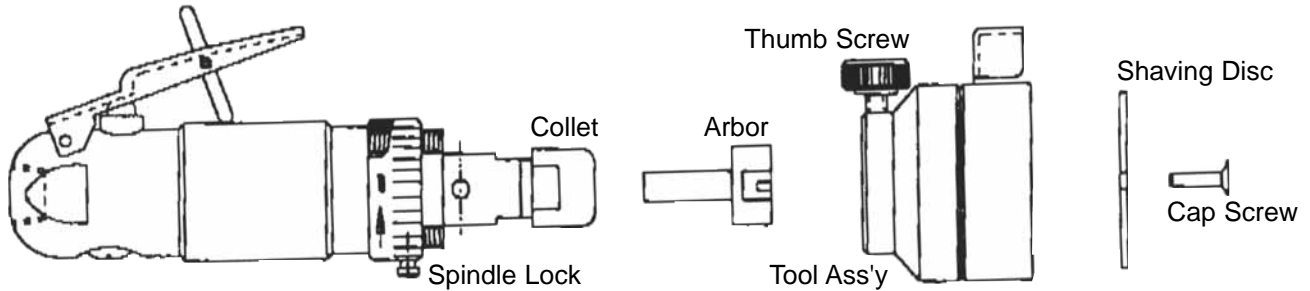

## Procedure for changing the arbor:

1. Depress the spindle lock button to prevent spindle rotation.
2. Use a 5/64" allen key to remove the cap screw.  
Remove cutting disc from arbor.
3. Loosen the thumb screw then unscrew the assembly.
4. Once again depress the spindle lock.
5. Using a 5/8" open end wrench, loosen the collet by turning it counterclockwise one complete revolution. Remove the arbor, insert the replacement then retighten the collet.
6. Screw the tool assembly back onto the air motor.

## Procedure for changing the cutting disc:

1. Depress the spindle lock button to prevent spindle rotation.
2. Use a 5/64" allen key to remove the cap screw.  
Remove cutting disc from arbor.
3. Peel away the adhesive strip on the new disc.  
Place disc on arbor by aligning the holes and lugs.
4. While depressing spindle lock, reinsert cap screw and tighten securely.

## Spare Parts Ordering Information

Item	Part No.	Description	Qty.
1	MAPS-01	Miller Ass'y w/Plastic Base	1
	MAPS-01B	Miller Ass'y w/Brass Base	1
2	MAPSD-01	Cutting Disc Ass'y	
3	MAPS-01-15	Flat Head Cap Screw	1
4	MAPS-01-100	Disc Mounting Arbor Ass'y	1
5	MAPS-01-05	Thumb Screw Ass'y	1
6	MAPS-01-07	Cutting Disc Housing (plastic)	1
	MAPS-01-07B	Cutting Disc Housing (brass)	1
7	MAPS-01-08	Wire Formed Retaining Ring	1

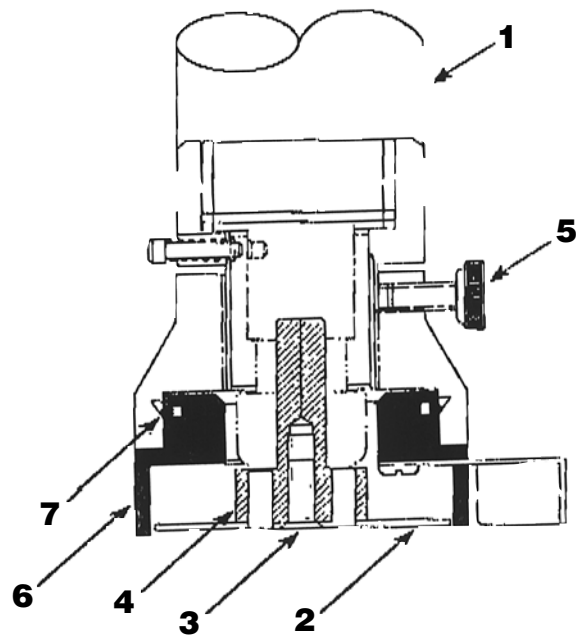

USATCO\U.S. Air Tool Company, Inc.

Eastern Division .....60 Fleetwood Ct., Ronkonkoma, NY 11779-6951 tel: (631) 471-3300 fax: (631) 471-3308

Western Division .....1219 W. Mahalo Place, Rancho Dominguez, CA 90220-5446 tel: (310) 632-5400 fax: (310) 632-3900