



53-400 Rivet Removal Tool

DRILL BIT REMOVAL AND REPLACEMENT

1. Back off knurled lock nut.
2. Remove drill guide.
3. Unscrew brass bushing at top of tool.
4. Remove drive shaft, spring and bit.
5. Remove drill bit from shaft and install desired drill bit.
6. Apply a drop of light machine oil on the drive shaft at brass bushing.
7. Install drive shaft and spring in housing and tighten brass bushing.
8. Install knurled nut on corresponding drill guide (#40 drill to #40 guide, etc.).
9. Reinstall drill guide in housing.

DRILL DEPTH ADJUSTMENT

1. Disconnect power tool from air or electric supply.
2. Install tool in drill chuck and tighten chuck.
3. Pull housing toward chuck until it bottoms on snap ring
4. Adjust guide to desired depth and tighten lock nut.
5. Reconnect tool to power supply and proceed drilling out.

DRILL RECOMMENDATIONS

1. During use, frequently dip the drill and bit in cutting fluid to keep cool and lubricated.
2. When drilling steel rivets or blind rivets with steel shank, use a slow drill speed and higher feed pressure.
3. Cobalt drill bits recommended for production work in steel.
4. Care should be taken to keep nosepiece clear of metal chips during drilling.
5. It is imperative to use properly sharpened drill bits.

Toll Free Nationwide & Canada: **800-645-8180**

USATCO\U.S. AIR TOOL COMPANY, INC. www.USATCO.com NEW YORK • CALIFORNIA

Rivet Removal Tool Parts List



No. 53-400

"Quickie" rivet removal drill-out assembly has an adjustment feature that limits drill penetration to actual rivet, not beyond. A must for repair work.

Includes: 1 each: #10, #21, #30 and #40 Drill Bits and Guides (4 bits & 4 guides)

Item No.	Quantity	Stock No.	Description
1	(1)	38-4001	Housing
2	(1)	38-4002	Shaft
3	(1)	38-4003	Bushing
4	(1)	38-4004	Spring
5	(2)	38-4005	Retaining Ring
6	(1)	38-4006	Washer
7	(1)	38-4007	Threaded Washer
8a	(1)	38-4008	Nosepiece (#10)
8b	(1)	38-4009	Nosepiece (#21)
8c	(1)	38-4010	Nosepiece (#30)
8d	(1)	38-4011	Nosepiece (#40)

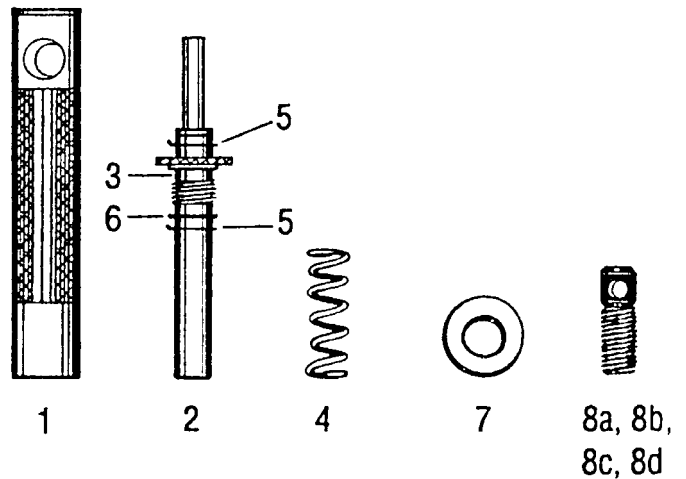

Replacement Drill Bits (1/4-28 Threaded Shank x 2-1/8 O.A.L.)



Stock No.	Size
02-2972-10	#10
02-2972-21	#21
02-2972-30	#30
02-2972-40	#40

No. 53-2972

*Four Piece Set of H.S.S.
Threaded Shank Adapter Drills*

USATCO\U.S. Air Tool Company, Inc.

Eastern Division60 Fleetwood Ct., Ronkonkoma, NY 11779-6951 tel: (631) 471-3300 fax: (631) 471-3308

Western Division1219 W. Mahalo Place, Rancho Dominguez, CA 90220-5446 tel: (310) 632-5400 fax: (310) 632-3900